

# BOUQUET PENDANT

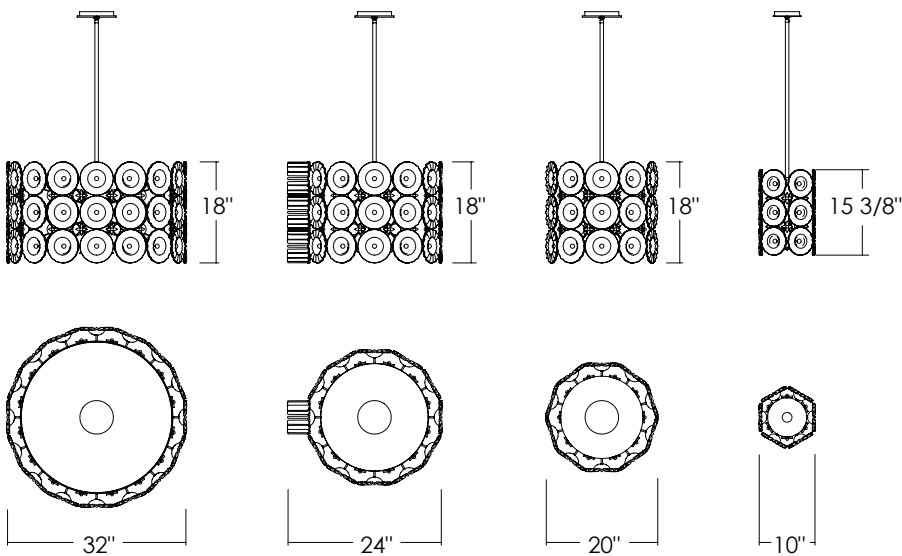

## Bouquet Pendant Configurations



*(continued on next page)*

11828 NE 112th Street  
Kirkland, WA 98033  
(tel) 425.823.4560 / 800.755.0471  
(fax) 425.823.8654  
sales@charlesloomis.com  
www.charlesloomis.com

June 2009

CHARLES LOOMIS, INC.  
*Loomis*

# BOUQUET PENDANT

## Bouquet Pendant Specifications



### Dimensions:

	Diameter:	Height:
P10	10"	15"
P20	20"	18"
P24	24"	18"
P32	32"	18"

### Material/Finishes:

#### *Metal:*

Stainless Steel Polished CL435

#### *Diffusers:*

Sheer Embossed Crystal Clear Glass  
Large & Petite Flowers

#### P10:

(15) Large Flowers &  
(10) Petite Flowers

#### P20:

(30) Large Flowers &  
(20) Petite Flowers

#### P24:

(36) Large Flowers &  
(24) Petite Flowers

#### P32:

(48) Large Flowers &  
(32) Petite Flowers

### Petite Flower Options:

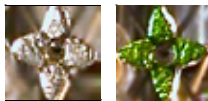

Clear

Green

### Supply Voltage:

120V

### Listing:

UL or ETL Dry Location

### Mounting:

P10: Direct to Junction Box

P24 to P32: Require Additional Mounting Points

### Fixture Weights:

P10 = 25 lbs.

P20 = 55 lbs.

P24 = 65 lbs.

P32 = 95 lbs.

### Lamping (Included):

P10: (6) T3 10W Halogen Clear

P20: (10) 40W G16 1/2 Clear

P24: (12) 40W G16 1/2 Clear

P32: (16) 40W G16 1/2 Clear

### Overall Drop:

To Be Specified — Stem Mount

### General Notes:

FOB - Kirkland, WA

Designed by Charles Loomis

**Please contact your local  
Representative for pricing and  
availability.**